

# **MODULAR DESIGN OF LI-ION & LI-POLYMER BATTERIES FOR UNDERSEA ENVIRONMENTS<sup>1</sup>**

**David A. White**

Southwest Electronic Energy Group

**ABSTRACT:** Li-Ion chemistry is ideal for undersea environments. The cells are sealed and do not out-gas and the polymer versions can withstand pressures greater than 10,000 psi. This combination results in a battery that is easier and safer to use and one that does not require heavy, expensive pressure vessels.

Recent advances in electronic control of the Li-Ion battery and new modular design concepts for construction of complex battery systems have resulted in battery systems that are more robust, more flexible, longer lived, easier to charge and maintain, and more safe than their lower density counterparts. These new Li-Ion battery systems can be designed to deliver this energy at high voltages and high currents. Electronic charge control within the battery system allows charging by direct connection to power supplies or constant power sources such as fuel cells and solar panels.

The modular design concept for Li-Ion and Li-Polymer battery systems are presented with an emphasis on construction for undersea applications. Key to the modular battery system design concept is the ability to electronically balance all the cells within the battery system automatically without operator intervention. Two different methods are described that show how electronic balancing of all the cells within the battery system are accomplished. Examples of production battery systems already in service are shown and systems under development are provided.

**KEY WORDS: MODULAR LITHIUM-ION UNDERSEA BATTERIES**

The battery industry is on the verge of a significant growth cycle in large format Lithium-Ion (Li-Ion) battery systems due to expected demand for electric land vehicles. Important to this growth is what was once thought of as a detriment of the Li-Ion chemistry – that it requires monitoring and control electronics for safety and for reliability. Engineers are turning this detriment into an advantage by using intelligent electronics to make battery systems that have capabilities that would not be practical, or even possible, without these electronic tools. While the land version of these battery systems is not necessarily suited for undersea environments, the same battery chemistry and electronics can be adapted for hadal zone regions deeper than 6Km. This article will show how a new concept of modularly designed Li-Ion and Li-Polymer batteries can be incorporated into marine vehicles that are not in the high production mainstream and that have the unique performance requirements of operation in a freezing and horrendously high pressure environment. This new battery system development methodology utilizes **battery modules** to construct complex battery systems.

## **CHALLENGES OF HIGH PRESSURE ON BATTERIES & ELECTRONICS**

People familiar with undersea batteries using the conventional lead-acid or nickel-cadmium chemistries know that even though the name of the cell or battery may contain the term “sealed”, these chemistries are not really sealed. They have to breath, and when they are being fully charged they have the nasty characteristic of giving off highly flammable and explosive gases. Therefore, discharge can be done in a sealed environment but full capacity charging can only safely be done in an unsealed and

vented environment. Where these cells cannot be vented (as in operation in an oil bath) it is possible to undercharge them to prevent out-gassing but this is at the expense of reduced life. The consequence, for safety reasons and when housed in a pressure vessel, is these batteries require the pressure vessel to be unsealed and vented during charge and resealed for use, with the nagging knowledge that multiple unseal and reseal cycles can result in leaks.

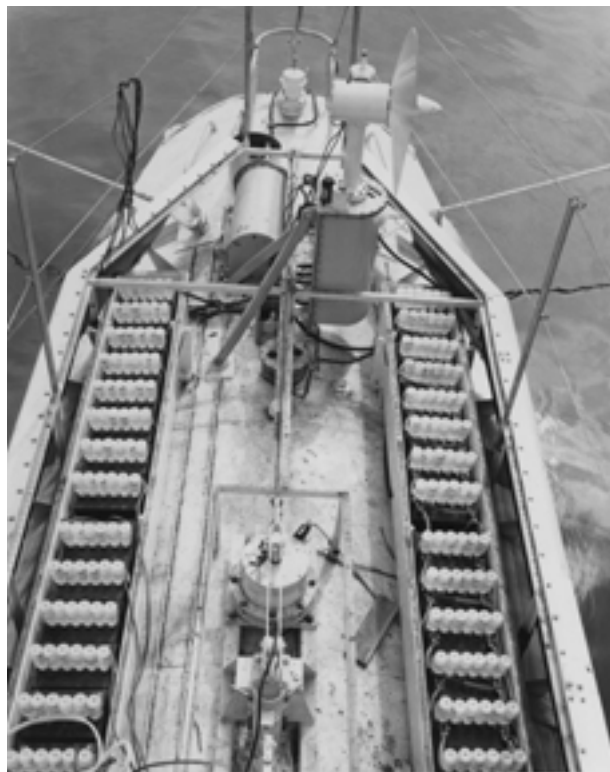

*Figure 1. Trieste's pressure compensated batteries are seen in two of the four external battery boxes with the lids removed. Batteries are overfilled with electrolyte in riser pipes, then the boxes are filled with oil. A compensating system provides additional fluid to the interior as pressure increases. Also seen are two of Trieste's five pressure compensated propulsion motors, plus the emergency ballast hopper release. (Photo:*

*U.S. Navy, courtesy Master Chief John Michel)*

Thus, a restriction on undersea missions using conventional rechargeable batteries is that the battery cannot be charged during the subsurface mission. This limits mission time to the energy capacity that can be carried on the exploration vehicle. If the battery could be charged, a low current tether could be used to maintain capacity of the battery system assuming its energy output is a mixture of low power observation current and high power current bursts for vehicle transient and positioning. Depending on the mission this could significantly extend mission time while keeping battery payload at a reasonable level. The problem of needing a significantly higher energy density battery and of longer or potentially continuous missions (manned or unmanned) is a severe restriction for conventional rechargeable battery chemistries.

Rechargeable Lithium-Ion (Li-Ion) cells and batteries, introduced in the 1990s, have matured and promise reduction or even removal of the restrictions of conventional battery chemistries. The rechargeable Li-Ion cell is not only 2 to 4 times more energy dense than other rechargeable chemistries, it is also truly sealed and can be charged and discharged without out-gassing. The only problem is that the chemistry is very sensitive to any contamination. If the cell's seal is broken, foreign material such as water or oils render the cell inoperative and may actually cause it to out-gas just prior to failure. For this reason, cylindrical Li-Ion cells that work fine within a pressure vessel cannot work at hadal zone pressures in oil submersion because there are air pockets within the metal encased cells. High outside pressure can, therefore, deform cylindrical cell cases and burst cell seals with resulting oil contamination and cell damage. However, as the Li-Ion technology maturity has continued, a new packaged form of the

same chemistry cell has been developed, called Lithium-Polymer (Li-Polymer). The Li-Polymer cell contains a Li-Ion chemistry that is housed within a sealed foil pouch. The pouch is vacuum sealed which removes almost all air pockets. When this cell is correctly constructed, it can be submerged in oil or flexible potting material. Charge and discharge cycling of cells has been tested at and above hadal zone pressures of 10,000 psi. The cell does expand and contract during charge and discharge cycling. Expansion and contraction volume changes are limited to 1% to 3% and, like hadal zone amphipods, internal and external pressure equalization allows this normal “breathing” function without damage to the cell. The difficulty presented by these new Li-Ion chemistries is that they require sophisticated electronics for monitoring, charge control, discharge control, and for balancing functions. Can these necessary electronics survive hadal zone pressures?

The majority of electronic components and integrated circuits used today are encapsulated in epoxy. This encapsulation typically allows these dense, complex electronics to be submerged in oil and exposed to crushing hadal zone pressures. However, not all types of electronic components can be used; for instance, any electronic components that contain air pockets such as electrolytic capacitors can be damaged by hadal zone pressures. Interestingly, the integrated circuits that conform to stringent military specs and that have traditionally been used in very high reliability military applications are almost exclusively housed in sealed ceramic chip carriers. These ceramic chip carriers contain air pockets under thin metal lids that will collapse at high pressures and, therefore, are disallowed for hadal zone environments. In fact, any sealed electronic component is suspect since sealed or potted components can contain

trapped air or vacuum spaces. Since electronics components are almost never specified for operation at pressure extremes, it is good practice to test finished circuit assemblies at pressure extremes to verify there are no component problems.

Having designed the electronics circuits and the cell assembly, a means to uniformly distribute external pressure to the assembly must be accomplished. Oil encapsulation is an ideal way to uniformly distribute external pressure and to fill air spaces between components and cells. However, oil can allow movement of the submerged parts that may be damaged by differing orientation or ship-board shock and vibration. Semi-firm potting tends to be more resistant to uncontrolled orientation, shock, and vibration. However, if components are potted, much care is required to select flexible potting and to guarantee that the potting fills all potential air pockets. This results in component orientation during the potting process, and the potting process itself, becoming critical. Finally, with oil or potting encapsulation, there is a necessity to seal the battery and the electronics away from salt water. This is typically achieved using housings which contain flexible bladder seals that allow for the finite compressibility of oils and potting materials at the extreme hadal zone pressures.

## **LI-ION SAFETY ISSUES**

A high hurdle to overcome in a Lithium chemistry battery system, where the battery energy density is many times higher than with previous chemistries, is safety. Designing a safe Li-Ion battery requires experience and a significant design effort. Safety is associated not only with use of the battery but also in transportation of the battery. When the design effort is completed its safety must be tested. Two

organization types are involved in regulating safety of Lithium chemistry batteries: transportation regulation organizations and military organizations.

The transportation regulations are something of a moving target because they are changing almost continuously. However, most countries, including the US Department Of Transportation (DOT), have settled on a common test requirement for Lithium chemistry batteries transported via air, land, or sea. This common test requirement is the UN Manual of Tests and Criteria commonly known as T1 through T8 tests. The UN tests for battery assemblies containing multiple battery cells require 16 to 24 completed battery assemblies. The tests typically irreversibly damage or destroy about half of these batteries and stress or use a portion of the cycle life in the other half. If the battery is large and expensive, these tests can result in enormous capital expenditures both for labor and for material. If the quantity of batteries produced is not very high, the cost of these tests can kill Lithium battery development projects.

The military regulating organization for undersea battery systems in the US is the US Navy. The US Navy has developed a safety handbook, NAVSEA S9310-AQ-SAF-010, which defines both assessment methods and destructive tests that must be performed on all Lithium chemistry batteries used in, or transported on, US Navy vessels. The assessment requires calculation and screening by safety engineer experts. The tests are designed to cause the destruction of the battery by high heat to determine the extent of potential damage that can result from the battery releasing its energy via either extended or violent battery disassembly. A safety determination is made by both the assessment and the destructive tests as to the potential for endangering personnel and the estimated cost of potential property damage. Fortunately, the destructive test does

not require a large quantity of test batteries. Never-the-less, both assessment and destructive testing are a significant expense for a large battery system especially where production quantities are not large.

## **BATTERY SIZE VS SAFETY, RELIABILITY, AVAILABILITY & MAINTENANCE**

How to resolve the safety problem that can result from the high energy potential of a large battery system and the safety testing expense of a large battery system is a significant hurdle. However, this is not the only hurdle. A large battery system that must operate in an extreme undersea environment can be particularly unforgiving should there be a component failure. Personnel danger, property loss, down time, mission failure, and significant maintenance expense are real risks in a large battery system. The system design must provide for reduction of personnel danger, property loss, down time, mission failure, and maintenance expenses.

Personnel danger can be reduced if safety is increased by using smaller batteries. Battery safety test costs are lower if the battery is smaller. Property loss is also reduced if the battery is smaller. Mission failure is reduced if the battery system has built in redundancy. Maintenance expenses and down time are reduced if failed components are smaller, less expensive, and easy to replace.

It is evident that the challenge is how to build a large battery system using small, identical, easily replaceable, component parts that work in a coordinated fashion, that can be individually safety tested, and that are constructed in situ in an arrangement that is inherently redundant. This is a tall order. However, there is a design concept for a Li-Ion battery that has potential for meeting all of these requirements – **Battery**

***Modularity.***

## **BATTERY MODULARITY CONCEPT**

Battery modularity design methodology is the construction of a complex rechargeable battery system using series and parallel combinations of identical, independent battery modules. Each battery module is a separable, self contained, rechargeable battery of a convenient size for on-site construction of multiple battery system applications and for meeting DOT requirements for transport safety.

A predecessor to modular battery construction concept is shown in Figure 2. Figure 2 is a photograph of a large, 25.9V, 356Ah Li-Ion battery. This battery, constructed for Applied Research Labs, utilized 36 battery modules. Four modules were built into a cylindrical layer and 9 layers were stacked on top of one another. The modules each had simple pack protect circuits to prevent over charge, over discharge, and over current. The modules were not separable, did not contain cell balancing or module balancing, and did not contain built in charge control. The battery had to be charged using a specially designed Li-Ion charger. Since this battery was constructed using cylindrical cells it had to be installed in a pressure vessel to maintain it at a nominal 1 atmosphere pressure during use at depth. The battery did not have to be unsealed during charging. Charging was done on the surface with the battery sealed within its pressure vessel.

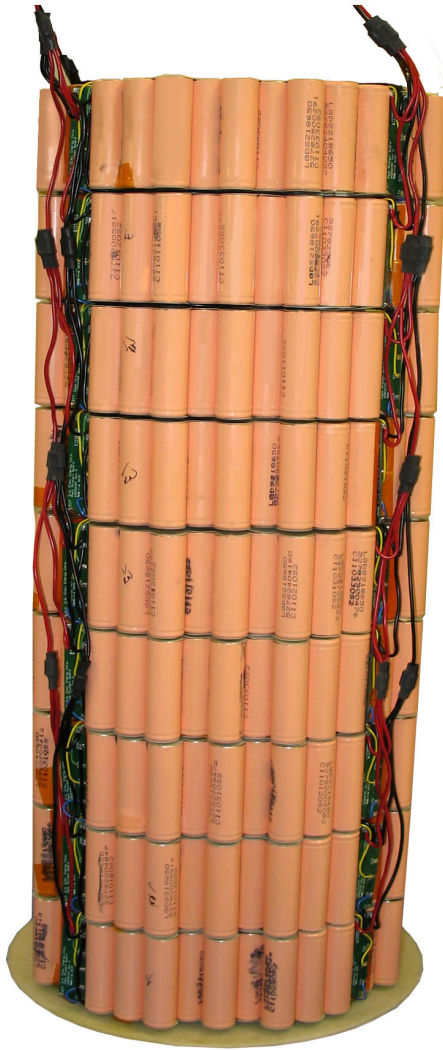

*Figure 2. Early Version of a Modularly Constructed Battery Pack.*

Today's modularity design methodology utilizes much more sophisticated module electronics. It does not require unique chargers for the battery system. Instead, it relies on the battery module having a means of internal charge control that allows it to be charged from multiple energy sources such as power supplies, solar panels, fuel cells, or combinations of these. A battery system constructed from these modules has the capability of using these multiple energy sources to charge the whole battery system while deployed.

Figure 3 is a smaller battery pack constructed using Li-Polymer cells. This battery pack, built for FMC Technologies, Inc., utilizes a 4 battery module section housed in a quarter cylinder case. Each one of these quarter sections is potted. The battery system contains 8 of these sections. Though the 4 modules are not separable, the battery sections are separable. Each section is mounted into a small pressure equalization housing containing pressure equalization fluid and a pressure equalization bladder. The system has a low current power tether that is capable of slow charging the battery pack to maintain it for continuous mission utilization. This battery system has been tested at 10,000 psi while performing low current charge and high current discharge.

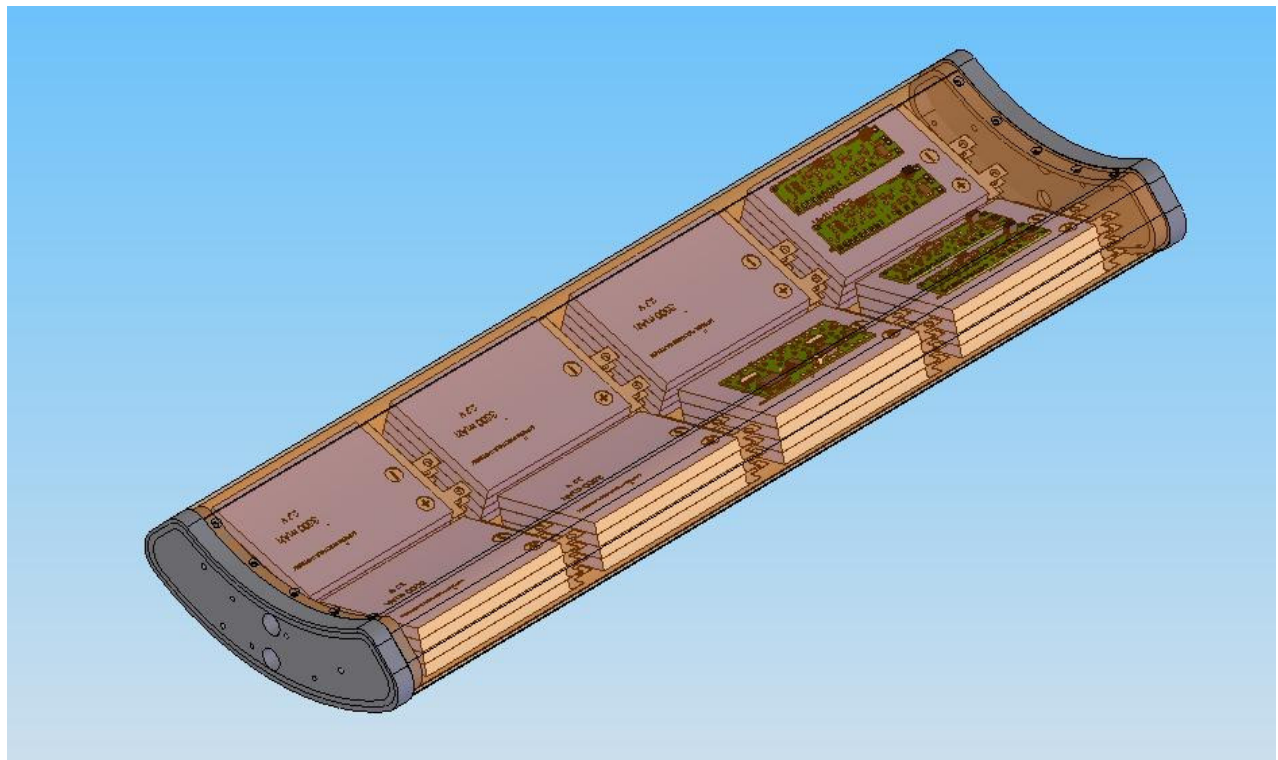
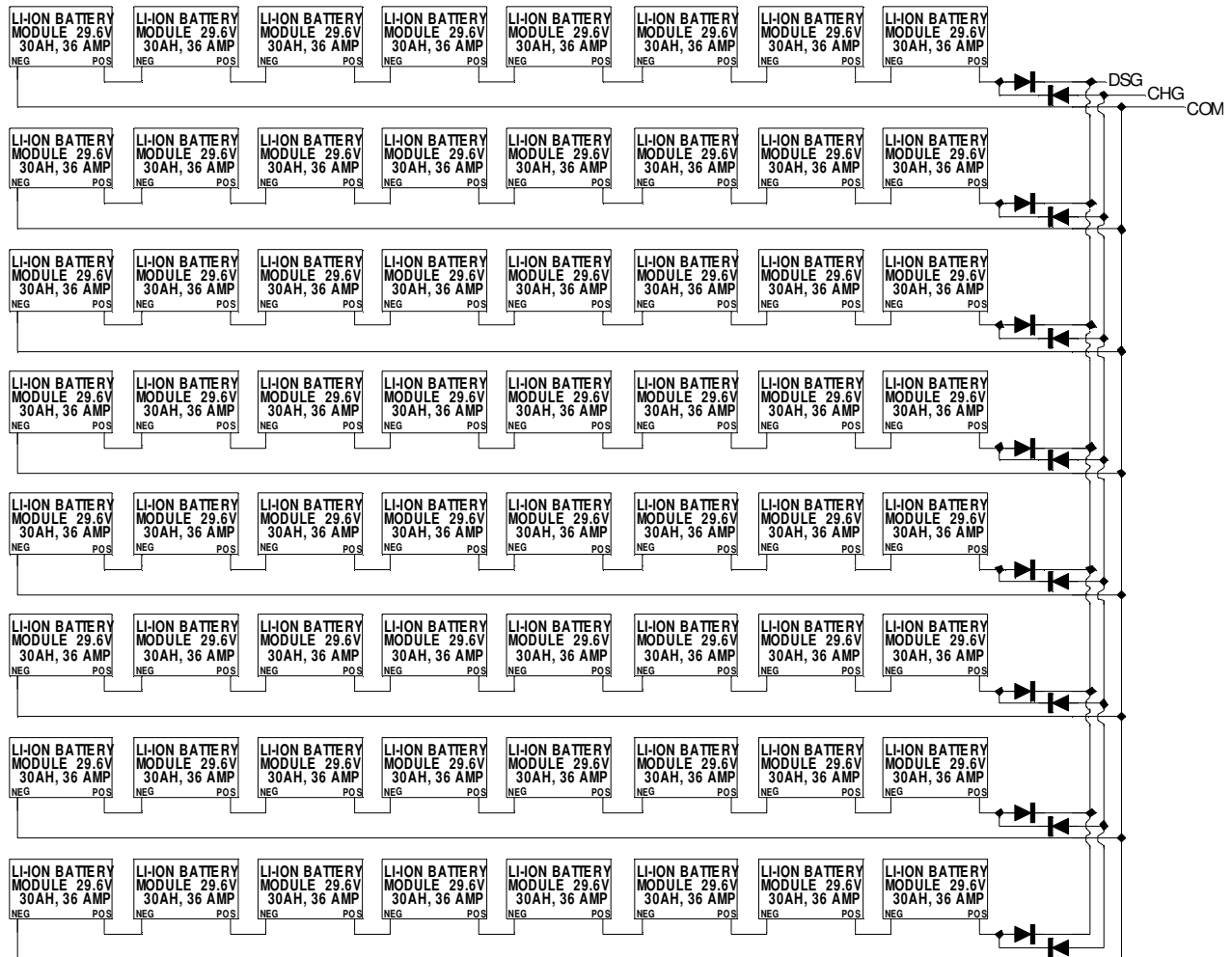

*Figure 3. Illustration of a Li-Polymer Battery pack Containing 4 Battery Modules*

Figure 4 is a schema of a proposed new battery system for the Alvin manned submarine at Wood's Hole Oceanographic Institute. This battery system is a large 47.2 – 56.6 KWh battery system constructed from 64 rechargeable and replaceable battery modules. Eight modules are series connected into an 8 series section of modules that are separated from one another by ideal Or'ing diodes. The Or'ing diodes prevent the failure of a battery section from affecting other battery sections thus providing redundancy of each section.

The system shown can be charged at 32 KW and discharged at 64 KW. The Alvin is not tethered; therefore, the battery system is surface charged prior to the subsurface mission. Full recharge time in this instance is as fast as 2 – 4 hours or can be slower depending on the constant voltage, constant current power supply used. Since the Alvin power requirements are 48 KW, this system can run at full power with as many as 2, 8-series sections (16 modules) disabled. The battery system is sized so that two of the battery systems shown can be attached to the Alvin for a total capacity of well over 100 KWh. Not shown is an RS-485, Modbus computer interface into each module. The computer interface will be utilized by the Alvin to monitor and control each battery module and the whole battery system.

## 236 VOLT, 200 - 240 AH LI-ION BATTERY PACK WITH >64KW CONTINUOUS OUTPUT POWER



*Figure 4. High Energy Battery System Constructed From Battery Modules*

### BATTERY MODULE ADVANTAGE SUMMARY

Advantages of constructing large battery systems using battery modules include:

1. Extreme flexibility of battery system design
2. Fast development
3. Cost reduced DOT testing
4. Increased safety in handling and shipping
5. Lower assembly costs

6. Lower repair & replacement costs
7. Lower inventory costs
8. Improved time-to-repair, and system availability

## **BATTERY MODULE REQUIREMENTS**

Construction of dissimilar battery systems using a multiplicity of the same battery module requires considerable foresight into the battery module design. Following is a list of typical requirements:

1. Fast and easy maintenance
2. Battery module replacement at any state of charge
3. Internal charge control
4. Configurable for distinctly different applications
5. High battery module reliability
6. Programmable architecture
7. Support for centralized status monitoring and remote control
8. Support for display of state of health, capacity, charge status, etc.
9. Chemistry agnostic
10. The key requirement: a means to balance all cells and all battery modules in the battery system.

## **WHY BALANCING IS THE KEY REQUIREMENT**

Modern Li-Ion cell chemistries are remarkably robust in their ability to maintain balance. Never-the-less, field return data on high series count batteries support the need for a robust balancing capability for complex battery systems. For high cell count

battery systems battery pack unbalance is the number one reason for pack failure. To understand why, consider the following:

1. The likelihood of imbalance increases with the number of series connected cells.
2. A larger battery pack has a greater likelihood of portions of the pack being at different temperatures.
3. Pack imbalance can be caused by differential leakage currents external to the cell such as:
  - a) Differential leakage currents within the pack-protect circuit itself,
  - b) Differences in the insulation resistance between cells, and
  - c) Humidity & condensation on the pack-protect circuit board and on the cell insulators.
4. Pack imbalance can be caused by inter-module or intra-module capacity differences due to:
  - a) Different lots of same cell,
  - b) Differences in module age, and
  - c) Cell electrolyte leakage, contamination, or other damage.
5. Replacement of battery modules typically requires a system re-balance due to:
  - a) The replacement module's capacity being different from other modules or
  - b) The replacement module's state of charge being different from other modules.

The resultant requirement is that a robust balancing capability must be designed into the whole battery system. In the instance where the module design concept is utilized, this means intra-module and inter-module balancing.

## EXAMPLE IMPLEMENTATION OF INTRA-MODULE AND INTER-MODULE BALANCING

### BALANCING

Electronic cell balancing is not new. Two common intra-module balancing methods are discharge balancing and charge transfer balancing.

Discharge balancing is balancing by discharging higher capacity cells until they match the capacity of the lowest capacity cells.

Charge transfer balancing is balancing cells by transferring charge from the higher capacity cells into the lowest capacity cells until the cell capacities are equalized.

Both methods can theoretically be done at any time and in any battery operating mode. Neither method will reduce the usable capacity of a battery pack from what it was prior to being balanced.

These two intra-module balancing methods are commonly only described for balancing across a complete, inflexible, battery system using centralized control. For highly configurable battery systems constructed from independent, rechargeable battery modules there is an unmet need for an inter-module balancing method. The following two methods, developed by Southwest Electronic Energy Group, meet this need<sup>1</sup>:

### ZENER DIODE INTER-MODULE BALANCING

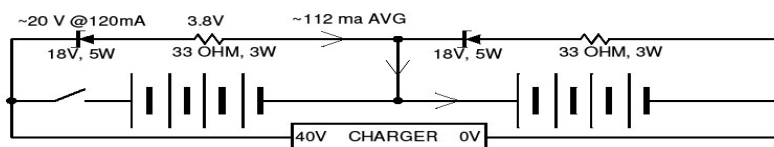

Figure 5. Zener Diode Inter-module Balancing Circuit

A simplified schematic of two, 4 series, Li-Ion battery modules that utilize Zener Diode Inter-module Balancing is shown in Figure 5. Assumed, but not shown, are the pack-protect circuits associated with each of the modules. The two modules in the

figure are unbalanced and are in the process of being charged. The first module has attained full charge status and its charge Field Effect Transistor (FET), shown as a simple switch, has opened. The other module is at a lower relative state of charge and has not yet attained full charge status. Charge current is bypassing the fully charged module via the Zener diode & current limiting resistor and is charging the module at the lower state of charge. The charge current will continue until both modules are balanced at which time the 2<sup>nd</sup> module's pack-protect circuit will open its charge FETs.

Figure 6 illustrates how Zener Diode Inter-module Balancing works. Each module in the example has internal charge control. Module 2 is at a higher state of charge than Module 1. At the beginning of the data set, Module 2 is near its end-of-charge cycle and has begun pulse charging – allowing charge current to flow into both modules in a pulsed fashion. When Module 2 is at full charge, it stops pulsing and opens its charge FET. Module 1 completes its charge using the bypass Zener diode current. When Module 1 has reached full charge status it also opens its charge FET. Both modules are now balanced and charge current stops going through the modules. Some small amount of quiescent current will bypass both modules as long as the charging power source is attached.

# ZENER DIODE INTER-MODULE BALANCING

DUAL 4S, 8.8Ah MODULES w/110mA BALANCING CURRENT

FULL CHARGE BALANCING 1Ah MODULE OFFSET

CHARGE - VOLTAGE: 40V, CV; CURRENT: 4 A, CC

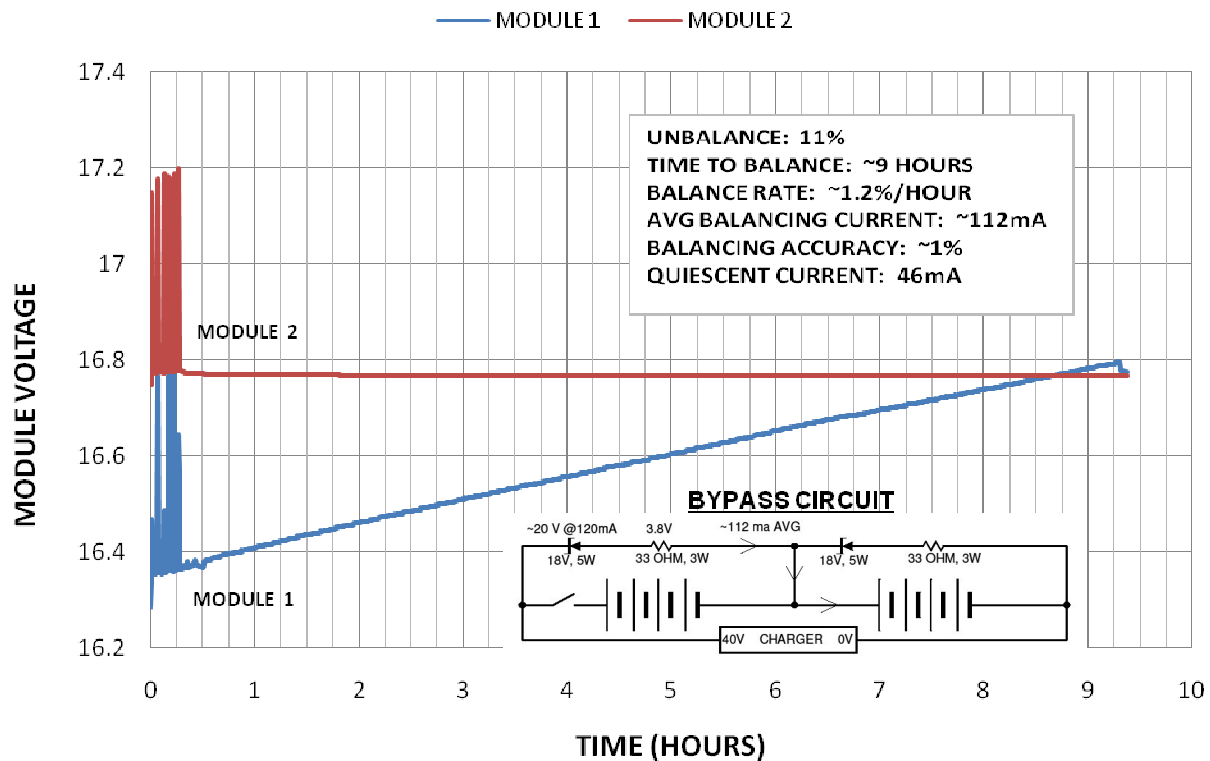

Figure 6. Zener Diode Inter-module Balancing Example

## DISCHARGE INTRA- & INTER-MODULE BALANCING

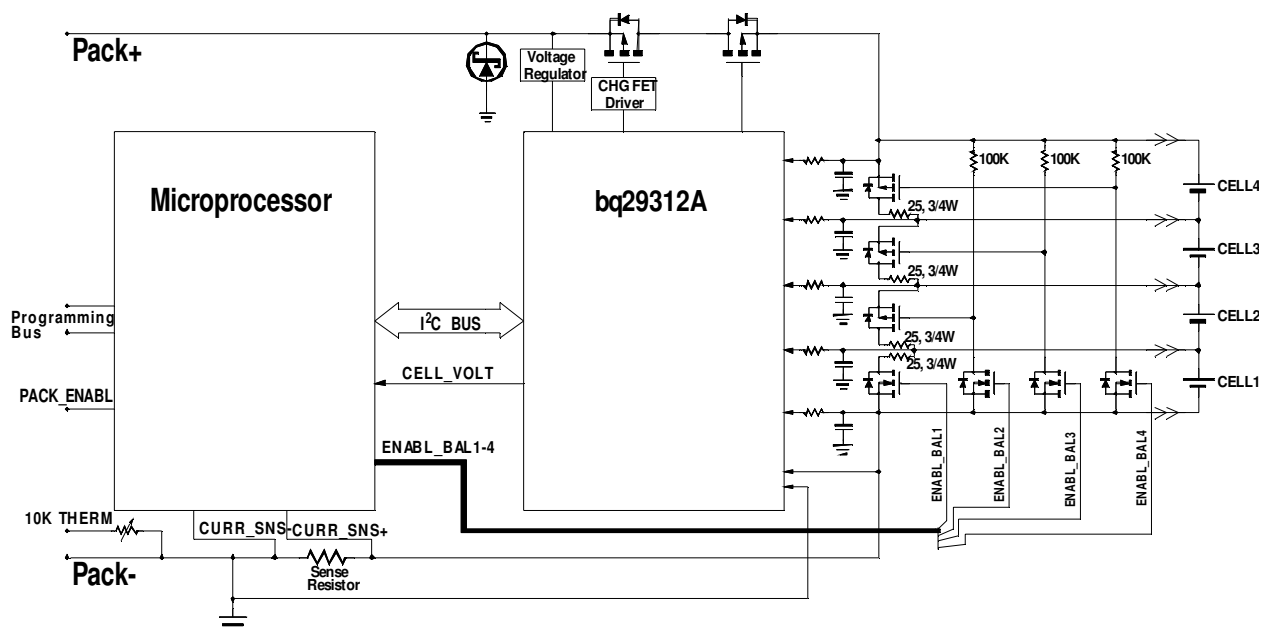

Figure 7. Discharge Intra- & Inter-Module Balancing Circuit

A simplified schematic of a 4 series battery module that includes the Li-Ion cells and the protect circuit is shown in Figure 7. The circuit in the figure is capable of intra-module and inter-module discharge balancing. The circuit is constructed using off-the-shelf parts including a microprocessor, an AD converter, an Analog Front End circuit, external balancing switches, and external discharge balancing resistors. An 8 amp implementation of the pack-protect circuit in Figure 7 will fit onto a 2.5" X .75" Printed Circuit Assembly (PCA).

As in the previous example, consider a battery system made from two, Figure 7 modules connected in series. Each Figure 7 module is able to balance the cells it is connected to using the external FET switches and the 25 ohm, 3/4W discharge resistors. This is conventional intra-module balancing. What may not be obvious is that each Figure 7 module, under appropriate internal software control, is also capable of

inter-module balancing with the other module connected in series with it without any control communication between the modules.

Figure 8 illustrates how Discharge Inter-module Balancing, using two Figure 7 modules connected in series, is accomplished. The two modules are programmed for intra-module charge control to 80% capacity as might be required in a battery back-up application. There are no control signals connecting these modules; the battery modules' external connections are only PACK+ and PACK-. A description of the action taking place in Figure 8 follows.

Prior to being balanced, Module 2 is at a higher state of charge than Module 1 – they are unbalanced. A 34 Volt, current limited power supply is connected across the two modules as a charge source. Module 1 has its charge FETs constantly on but Module 2 is close to being fully charged so it pulses its charge FETs reducing average charge current. The pulsed charge current from Module 2 charges both Module 2 and Module 1 until Module 2 reaches 81.5% capacity, opens its charge FET, and stops pulse charging. Between charge pulses, Module 2 discharges itself down to 80% capacity by enabling all 4 of its balancing resistors. Module 1 does not discharge itself during this time because it has not reached 81.5% capacity. When Module 2 discharges down to 80% capacity it begins pulse charging once again until it again reaches 81.5% capacity and opens its charge FET. Thus, Module 2 charges and discharges itself between 80% and 81.5% capacity while Module 1 only charges without discharging. This continues until Module 1 attains the same 81.5% capacity at which time the two modules become balanced. Once balance is attained, both modules continue to perform 1.5% capacity charge – discharge mini-cycles. Pulse charge current range is approximately 2.2 to 3

amps due to 0.44 ohm resistor in series with the 34 Volt charge source. Charging and discharging mini-cycles of 1.5% at about 80% capacity is not stressful on the cells. Cycle rate is about 0.8 cycles per hour, 19.2 cycles a day, 7008 cycles a year. If end of life of a cell is set at 80% of its full charge capacity, an obvious question is how many of these mini-cycles does it take to cause the cells to reach end of life? Some NASA studies indicate this number may be in the 10s to 100s of thousands. Thus, it is expected that continuous mini-cycles such as this do not appreciably affect battery module life. Never-the-less, if mini-cycles are objectionable, it is possible to lengthen them or cause them to stop altogether once balance is attained.

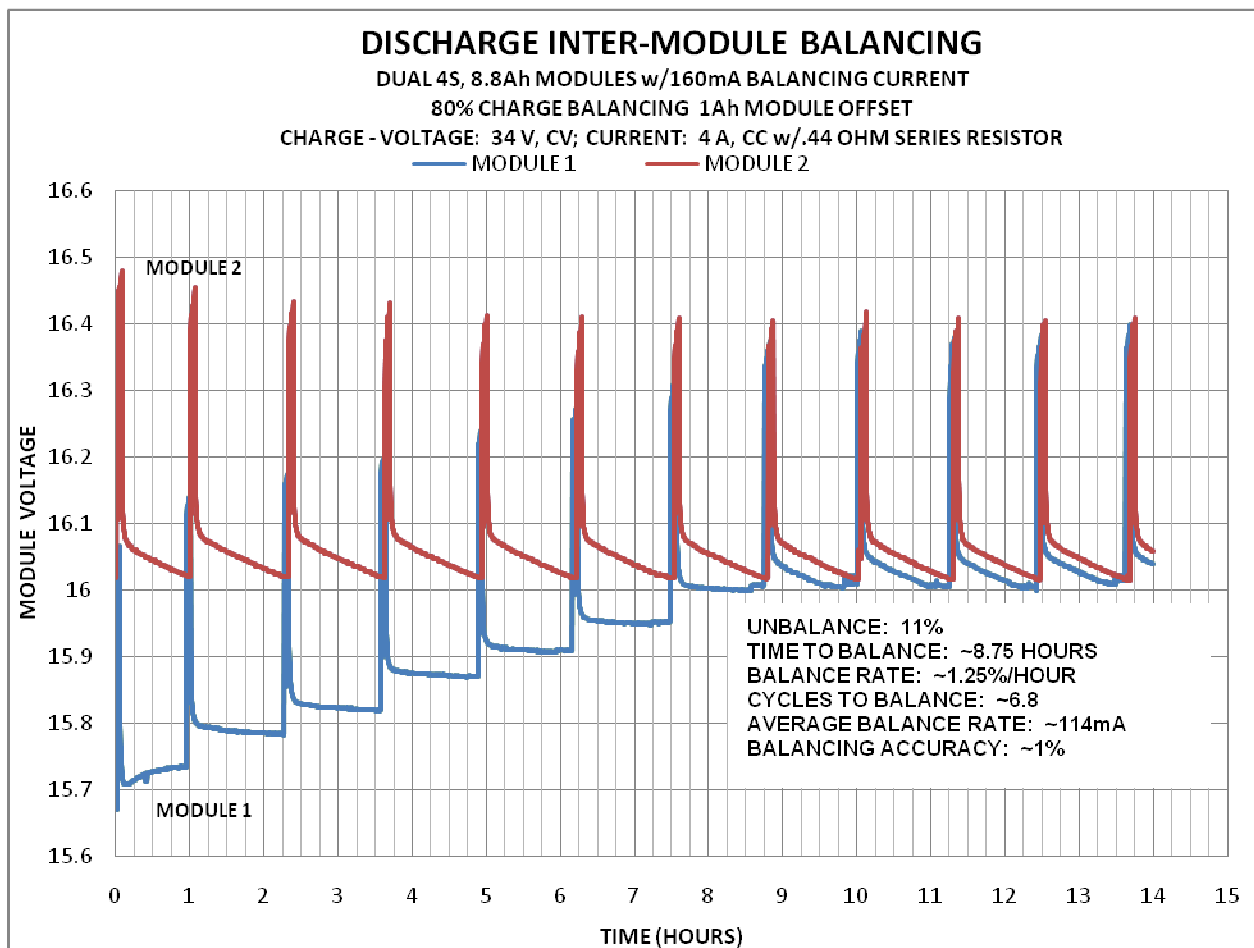

Figure 8. Discharge Module Balancing Example

The previous examples were Inter-module balancing examples. Continuous Intra-module balancing has been suggested to compliment the charge only Inter-module balancing. If continuous Intra-module balancing is used, each of the modules would typically always be in balance internally and would not need to be balanced prior to Inter-module balancing. Figure 9 illustrates the effect of modifying Intra-module balancing so that it is not done continuously but only during charge. This is not recommended but is shown to demonstrate the advantage of doing continuous Intra-module balancing instead of charge only Intra-module balancing.

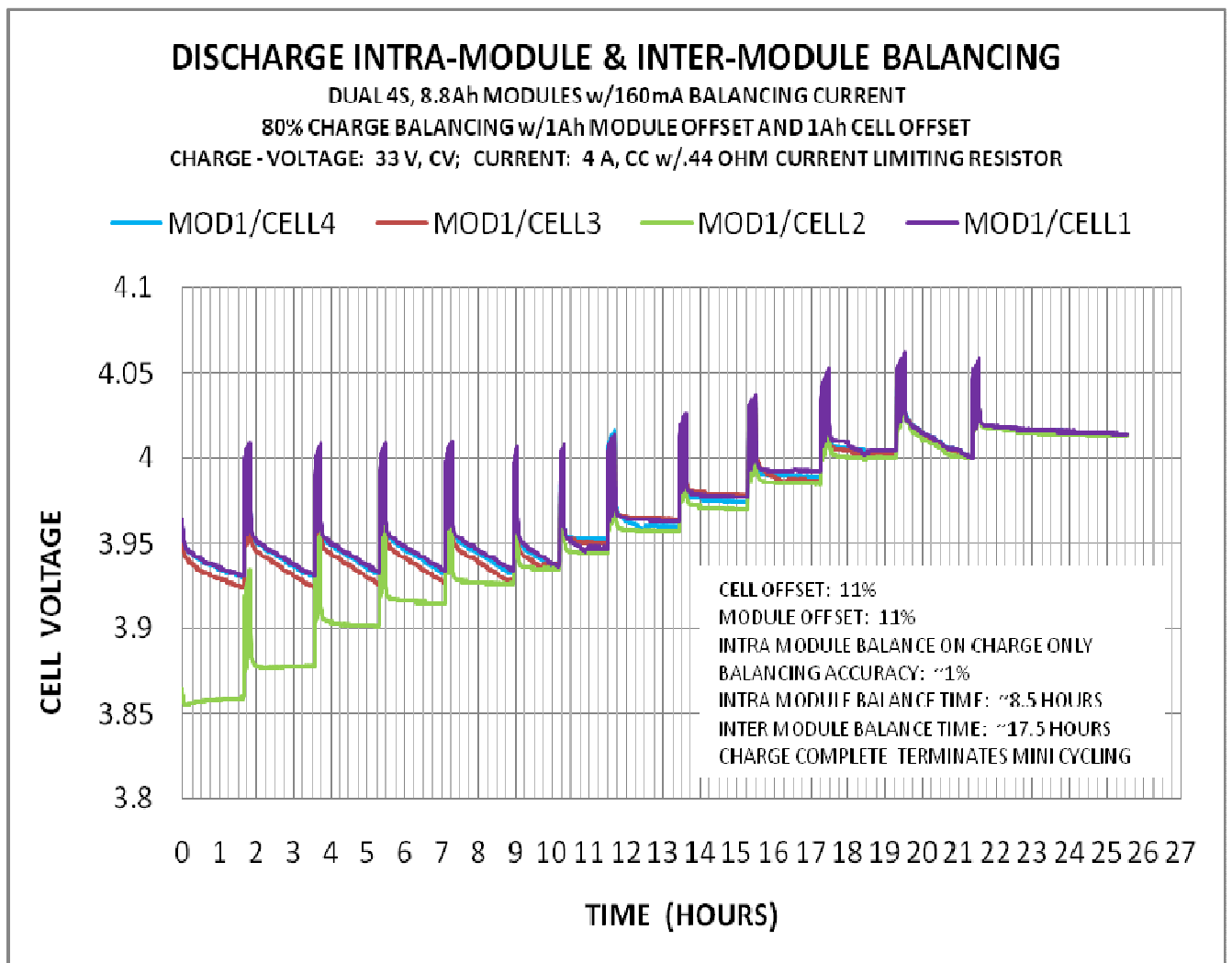

Figure 9. Combined Intra-Module & Inter-Module Balancing Example

In Figure 9 Intra-module continuous balancing was modified to perform balancing only during charge so the interaction of Intra-module and Inter-module balancing could be demonstrated. The graph in Figure 9 shows the individual 4 cell voltages of Module 1 only. Cell 2 in Module 1 is out of balance with the other cells in this module. Simultaneously, Module 1 is out of balance with Module 2. Both Intra-module and Inter-module balancing need to happen to bring the whole battery system into balance. A new feature, charge complete detection, was added to allow termination of mini-cycles very soon after the modules obtained balance. For simplicity, Module 2 is not shown on the graph. Module 2 is accomplishing mini-charge/discharge cycles similar to what was shown in the Figure 8 example.

The example in Figure 9 illustrates the capability of automatically balancing all the cells across a complex battery system to within about 1% of one another and of terminating mini-cycles when balancing is obtained. All of this is accomplished using autonomous modules with no required central control and no required communication between the modules. The advantage of continuous balancing within a module is apparent in this example. Notice that fully half the balancing time is spent doing Intra-module balancing. Once Module 1 cells have been internally balanced then Inter-module balancing happens. If continuous balancing had not been disabled in Module 1, the Module 1 would have already been internally balanced and Module balancing time would have been cut in half as in Figure 8.

Discharge Inter-module balancing and Zener diode Inter-module balancing were previously shown separately. It is possible to combine these two Inter-module balancing methods. Figure 10 illustrates the effect of combining these two methods.

Again, for simplicity, only Module 1 is shown in Figure 10. Module 2 is simply accomplishing mini-charge/discharge cycles. Notice that the combination of Zener diode Inter-module balancing and discharge Inter-module balancing, as expected, speeds time to balance by about a factor of 2. Because the Zener diode Inter-module balancing method requires a relatively large charge voltage to be effective, it is very difficult to prevent the module balancing mini-cycles. This kind of module balancing would be especially useful for fully charging and module balancing a complex battery system in the shortest time. Terminating charge when the modules come into balance would limit the number of mini-cycles.

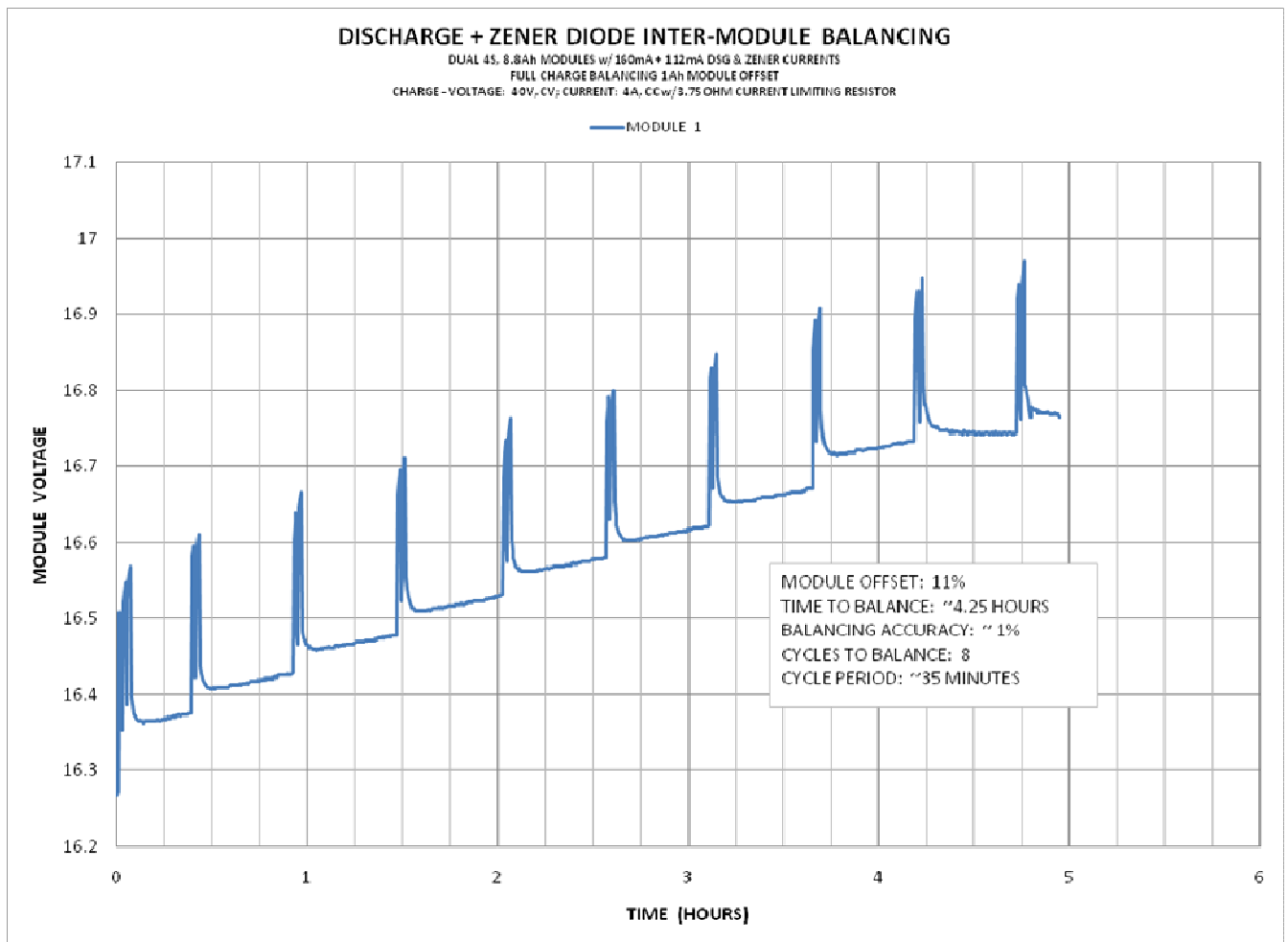

Figure 10. Combined Discharge & Zener Diode Inter-Module Balancing Example

The previous examples concentrated on the portion of the charge cycle where Inter-module balancing was happening at a time when two modules were badly out of balance. Figure 11 is a more typical example of a normal charge cycle of two series connected modules that are fully discharged and are very close to being balanced. This example allows one to gain perspective on the portion of a charge cycle that is involved in the Inter-module balancing activity. Again, for simplicity, only Module 1 data is shown. Notice that Inter-module balancing does not come into play until the end of the charge cycle. It does not extend the charge cycle time unless it is needed. A slight imbalance is present which is corrected between the 3.8<sup>th</sup> hour and the 3.9<sup>th</sup> hour of charge. Charging was continued with about 4 mini-cycles after balance was achieved.

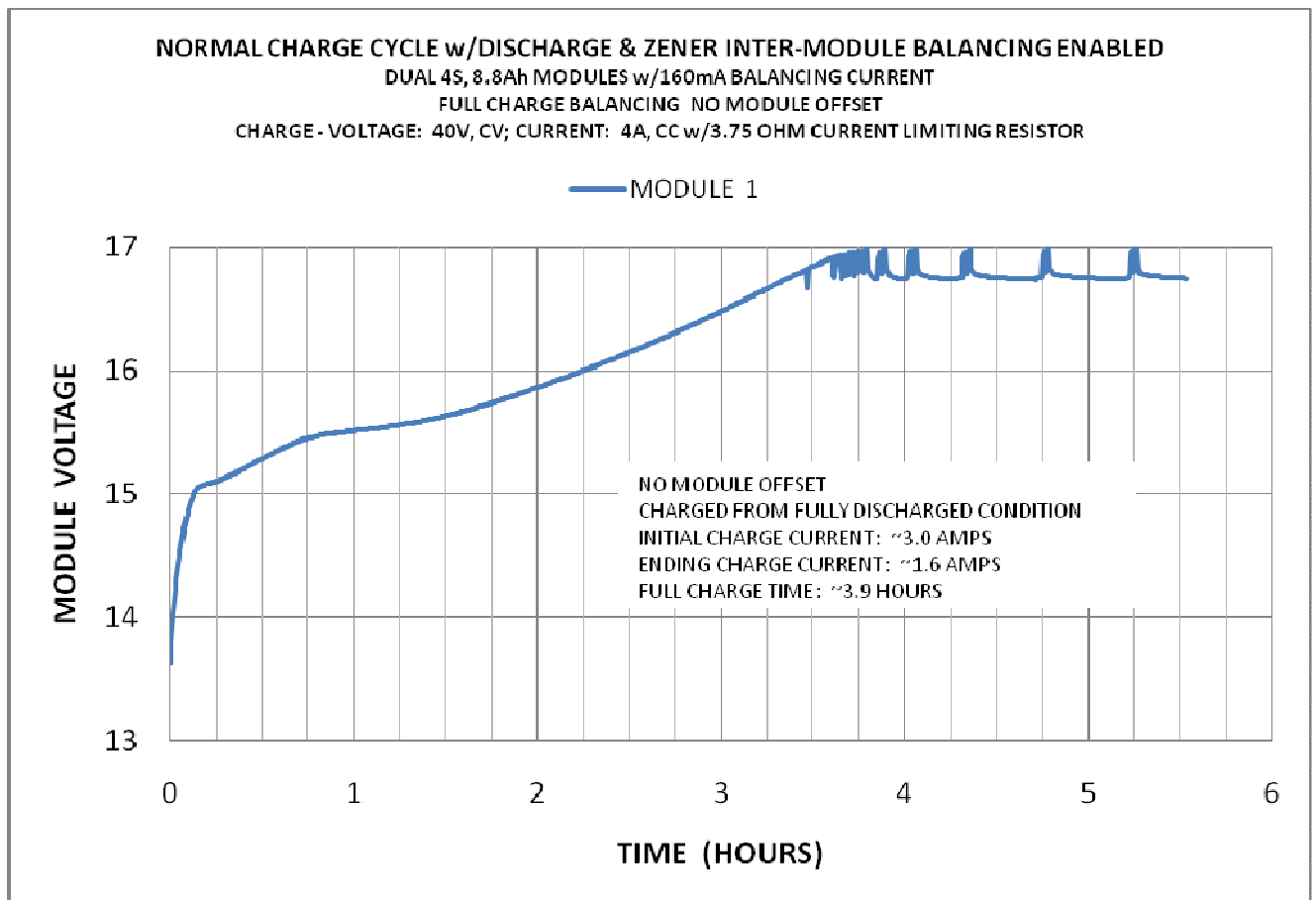

Figure 11. Example of a Full Charge Cycle When Inter-Module Balancing is Enabled

## CONCLUSIONS

The Lithium-Ion polymer version of Lithium-Ion cells have been successfully tested for both charge and discharge at pressures experienced in hadal zone regions. Since the energy capacity of Lithium-Ion cells is 2 to 4 times that of conventional chemistry cells, operation at depth is significantly extended when using these cells. The Li-Ion chemistry does not out gas during charge or discharge and can, therefore, be safely housed within sealed containers without the necessity of unsealing and ventilating the container during charging. This feature allows faster, safer, and more reliable re-deployment of Lithium-Ion powered marine systems. It also allows the potential for continuous operation at depth when a charging umbilical is used.

Electronic balancing is a requirement for large Lithium-Ion battery systems because the chemistry does not provide for overcharge balancing as do previous rechargeable chemistries. Engineers, having to live with this restriction, are discovering that the ability to automatically electronically balance all parts of a complex battery system leads to new paradigms in battery system design, use, and maintenance that are only recently becoming evident. Among these are:

1. Use of battery modules to enhance safety & reliability and to reduce costs.
2. Applying electronic balancing to other, non Li-Ion, rechargeable chemistries
3. Increased number of series connections in a battery
4. Increased flexibility in modularity & replaceable unit concepts
5. Smarter battery systems
6. More flexible charge control
7. Multiple charger energy sources

8. Potential for multi-energy source hybridization
9. Potential for construction of multi-voltage, multi-capacity battery systems each having intra-module and inter-module balancing capability and each constructed using the same type of battery modules in each system

*NOTE 1: The methods in this article are protected by US patents 7,609,031 B2; 7,279,867 B2; and other US and international patents already granted or pending.*